



Professional Thick Plate Laser
Welding Solution Provider

Thick Plate Air Laser Welding Machine

Powerful Thick Plate Welding
Capacity - Born for Heavy Industry



Kempson Everlens Welding 1+N Series Products
Redefining Welding Economics: Your Optimal **Full-Life-Cycle Cost-Effectiveness** Solution

In industrial welding, two "invisible black holes" devour your profits

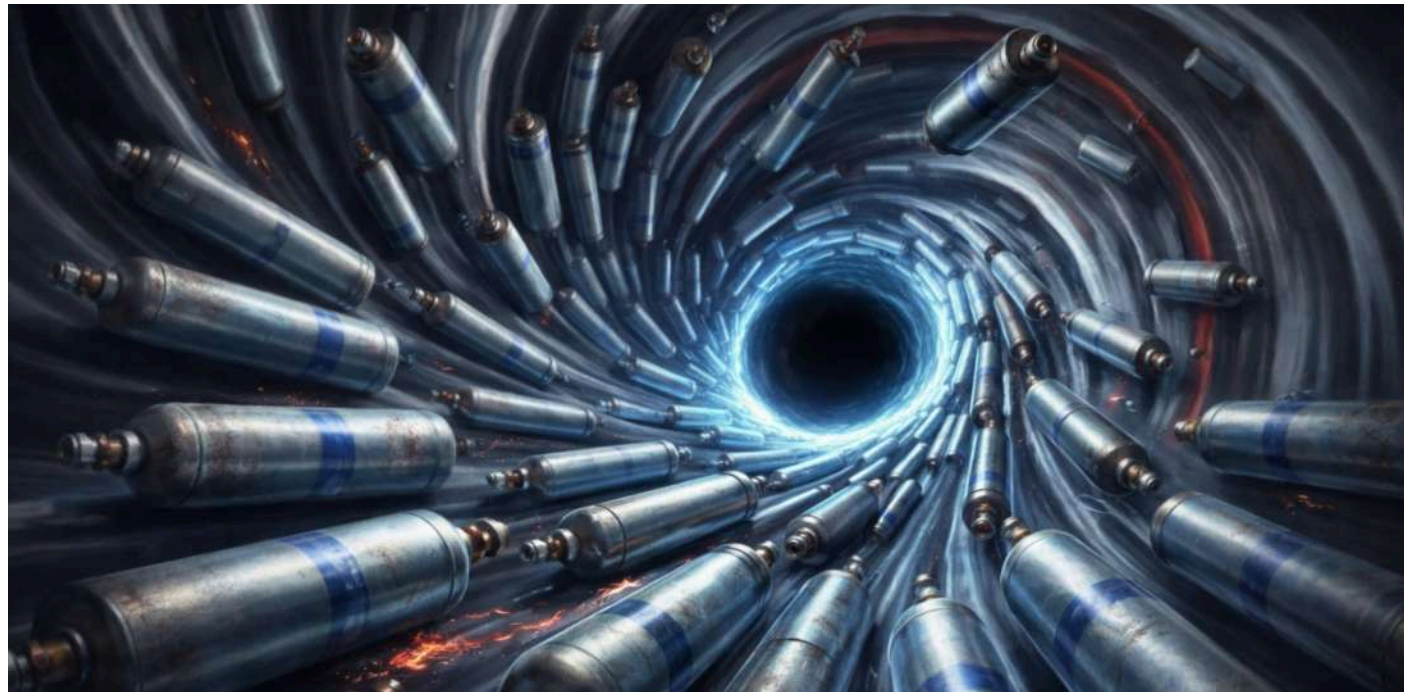

Black Hole 1

Endless Consumption of Shielding Gas Cylinders

Continuous procurement costs, complex logistics management, and potential storage safety hazards constitute a substantial fixed expense in production.



Black Hole 2

Fragile Shielding Lenses

It's an industry "rule" that lenses are high-frequency consumables. Under harsh working conditions such as steel structure and hardware processing, the service life of lenses is even calculated in "hours" or "shifts".

Pain Point: During an 8-hour shift, it may be necessary to replace more than a dozen lenses. Each shutdown for replacement interrupts the production rhythm, and the accumulated consumable costs become a heavy burden.

You have **more hidden costs** to bear

Equipment procurement price

Shielding gas costs

The procurement, transportation, and replacement of shielding gas cylinders are not only repetitive expenses but also bring cumbersome logistics management challenges.

Shutdown and downtime costs

Operations such as cylinder replacement, maintenance of worn parts, and handling sudden failures will cause production interruptions and waste working hours.

Consumable wear costs

Vulnerable parts such as shielding lenses are consumed quickly and need frequent replacement, constantly pushing up equipment operating costs.

Post-welding processing costs

Traditional welding produces rough and uneven welds, requiring additional manpower for grinding and trimming.



When enterprises purchase industrial equipment, they often focus on the initial purchase price. However, this is like the tip of an iceberg above the sea - the explicit cost is only a small part of the total cost. The real cost of a welding machine actually includes various "hidden costs" that continuously arise throughout the equipment's entire lifecycle. These costs will continuously erode the enterprise's budget and reduce production efficiency.

Beyond One-Time Price, Focus on Total Cost of Ownership (TCO)

“

We deeply understand that compared with the one-time purchase price, the Total Cost of Ownership (TCO) is the key factor determining production efficiency. The Kempson Air Laser Welding Machine is a groundbreaking product innovatively developed from the ground up. Its core design goal is to accurately target and completely eliminate these hidden costs, making professional welding operations more efficient and economical.

”



Technological Revolution **Against Ongoing Costs**



> Breakthrough Technology

> Powerful Performance

> Self-Developed High Quality Step Wire Feeder



Breakthrough 1

Subversive Innovation Challenging Industry Norms - **The Birth of "Everlens"**

The Innovation Story Behind Everlens Welding

"Faced with mountains of discarded lenses, the Kempson R&D team set a goal: to break the industry curse of 'laser welding must consume consumables'. **After 18 months and more than 1,200 material tests and structural iterations**, a subversive protective lens system was born."



Everlens System: Multi-Protection, 8x Longer Life

Eccentric Rotation Design (3rd Layer Protection)

The unique design enables contaminated lenses to be rotated for secondary use, significantly saving lens costs.

Shielding Lens (4th Layer Protection)

The unique design allows contaminated lenses to be rotated for secondary use, directly saving 50% of lens costs.

Focus Lens

Splash-Proof Special Welding Nozzle (1st Layer Protection)

The upgraded splash-proof welding nozzle significantly reduces spark impact and greatly lowers the risk of lens breakdown.

Splash-Proof Special Welding Torch Tube (2nd Layer Protection)

The second layer of splash protection reduces spatter by more than 75% compared with traditional welding torches, better protecting the lens and extending its service life.

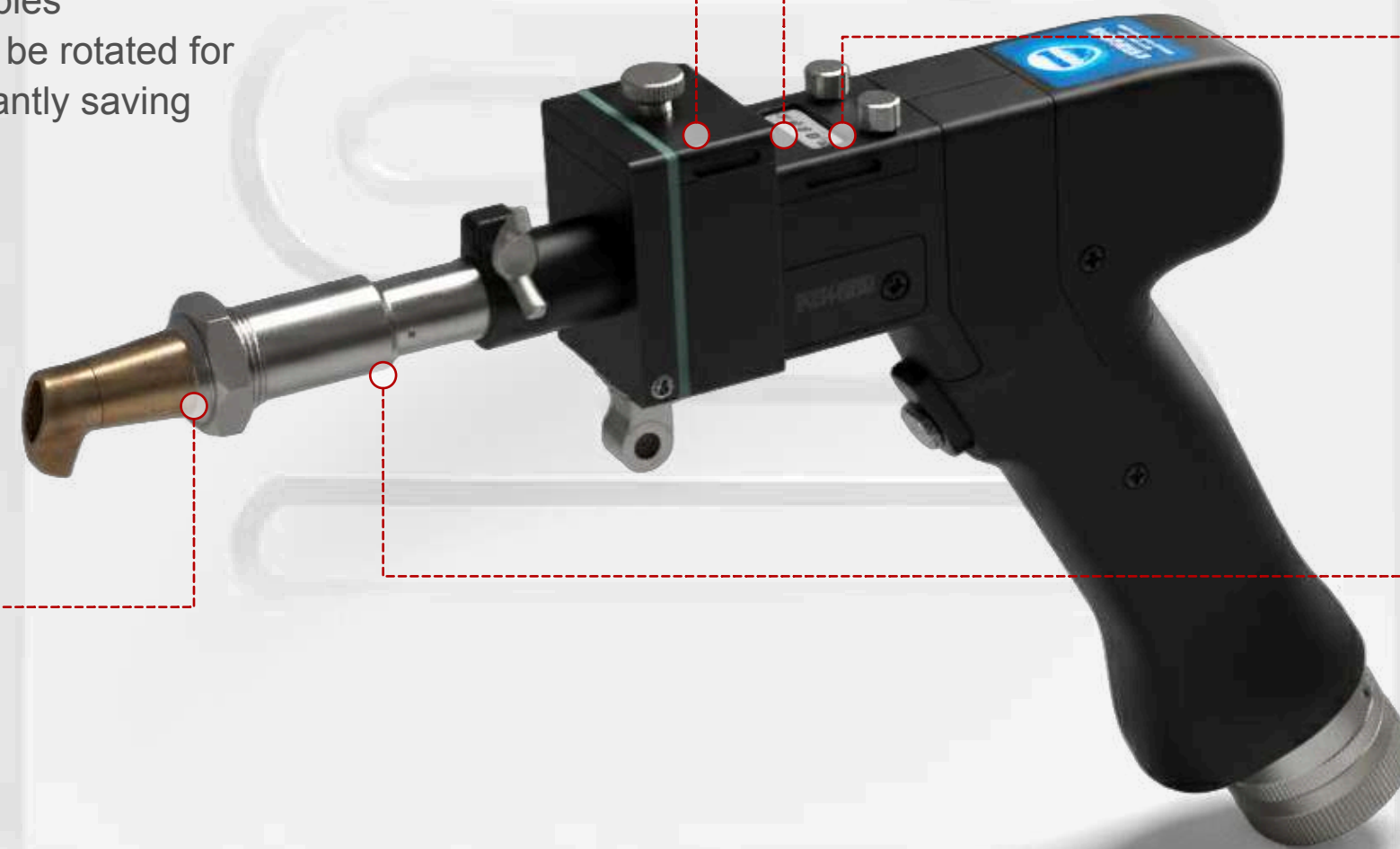

Note: All Kempson laser welding equipment is equipped with the Everlens Welding System.

Breakthrough 2

Bid Farewell to Cylinder Dependence and Achieve Self-Sufficiency in Shielding Gas



Working Principle

Adopt Korean-imported multi-stage scroll collision separation and filtration technology and high-precision gas generation system to directly convert air into high-purity inert shielding gas required for welding.

Core Advantages



Cost Savings

Eliminate the costs of purchasing, leasing, and transporting shielding gases such as argon.



Efficiency Improvement

No need to interrupt production for cylinder replacement, ensuring continuous operation.



Simplified Management

Get rid of the warehousing, safety management, and supply chain challenges of gas cylinders.

Value Verification in Real Industrial Scenarios, with Annual Savings of Approximately 50,000 USD

\$50,689 USD

A laser welding machine integrated with the self-developed Everlens Protection System and core technologies for in-house produced shielding gas has been officially put into operation at a large-scale steel structure plant in the United States. Compared with traditional welding equipment, the customer has calculated key cost optimization data: By virtue of the robust protection of lenses by the Everlens Protection System and its adaptation to welding conditions for plates of varying thicknesses, annual savings on lens consumables range from 9,655.8 to 14,485.8 USD; leveraging the precise compatibility of self-produced high-purity shielding gas to meet the diverse requirements of welding workpieces of different sizes, annual procurement costs for shielding gas are cut by 12,054 to 36,204 USD. More importantly, there is no need for shielding gas cylinder replacement, and the lens replacement frequency is reduced by over 80%. This translates to a substantial decrease in downtime costs and a marked improvement in the Overall Equipment Effectiveness (OEE).

"Redefining Welding Economics" is not an abstract concept, but a full-process production cost optimization solution tailored to customers. Its value has been fully validated in industrial practice.

Custom-Developed for Harsh Production Environments - **More Than Just Saving Consumables**



Powerful Heat Dissipation

Customized and enlarged high-efficiency water cooling system **supports 24/7 continuous operation.**



GW Laser

High Efficiency, Deep Weld Penetration, Anti-High Reflection Technology, and Low Power Consumption.



Isolator & Filter

Isolate radio wave interference to laser welding and filter power supply clutter generated by argon arc welding and MIG welding.

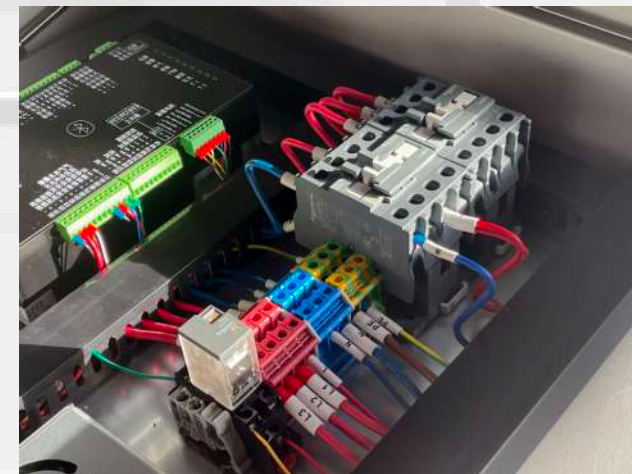

Electrical Components

Adopt Schneider Electric (France) with stable performance and long service life.

Powerful Thick Plate Welding Capacity

12mm

Maximum Weldable Thickness

8mm

Maximum Wide Weld Bead

For plates below 8mm, single-side welding with double-side forming can be achieved, perfectly meeting the stringent requirements of heavy industry customers such as steel structure and shipbuilding.

Self-Developed Stepper Motor System - Guarantee of Excellent Welding Results

Built-in calibration system to prevent wire jamming

Precise and stable feeding when using a single thin wire

Service life of more than 6 years

Four-wheel drive wire feeding, supporting free switching between single-wire, double-wire, and triple-wire modes. Precise and stable feeding when using a single thin wire for thin plate welding; double-wire feeding produces wider and fuller weld beads; triple-wire feeding is suitable for thick plate build-up welding, compatible with both thin and thick plates.



See for Yourself: **Excellent Welding Process**

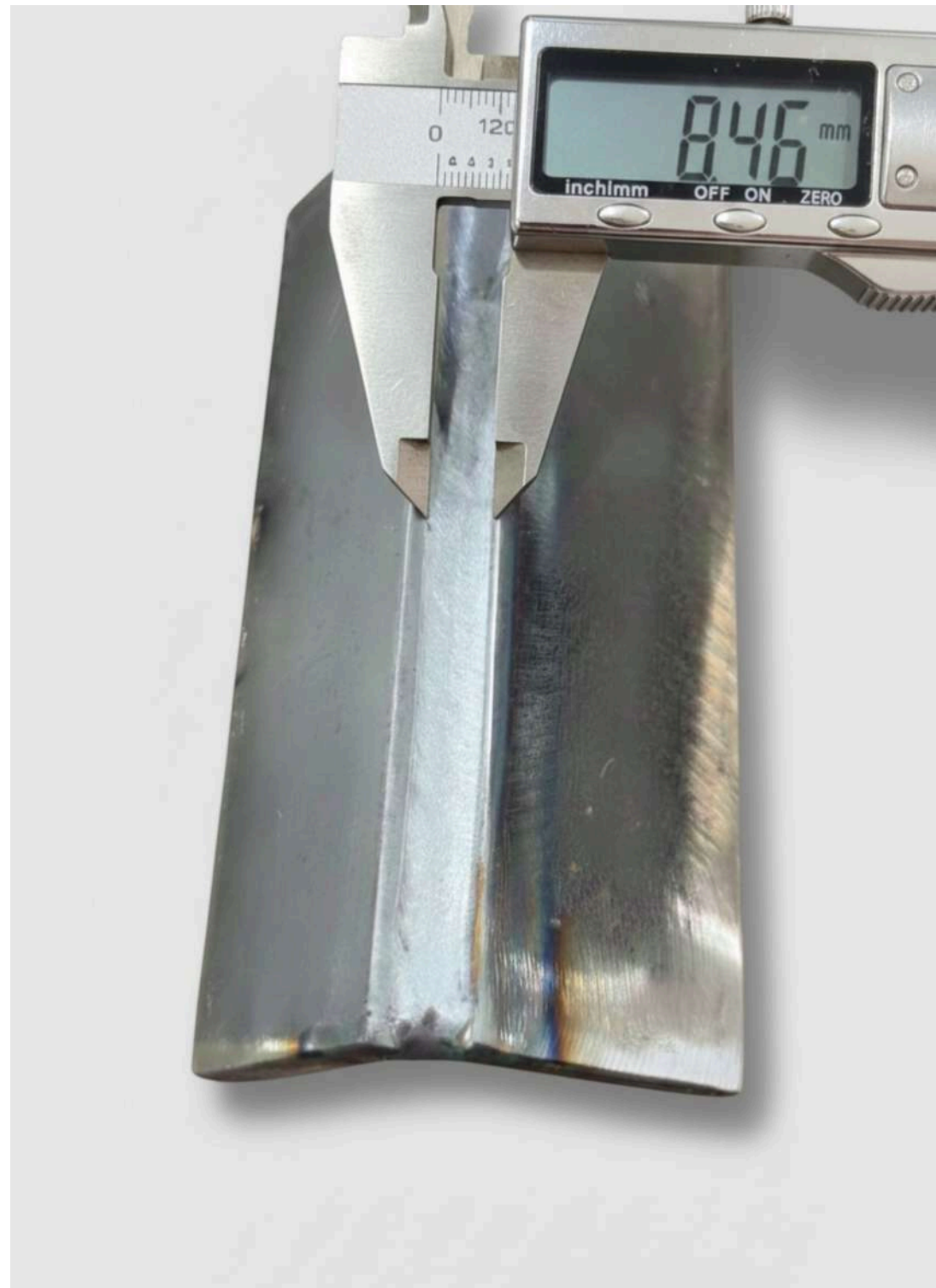

Wide Weld Bead 



12mm Thick Plate 

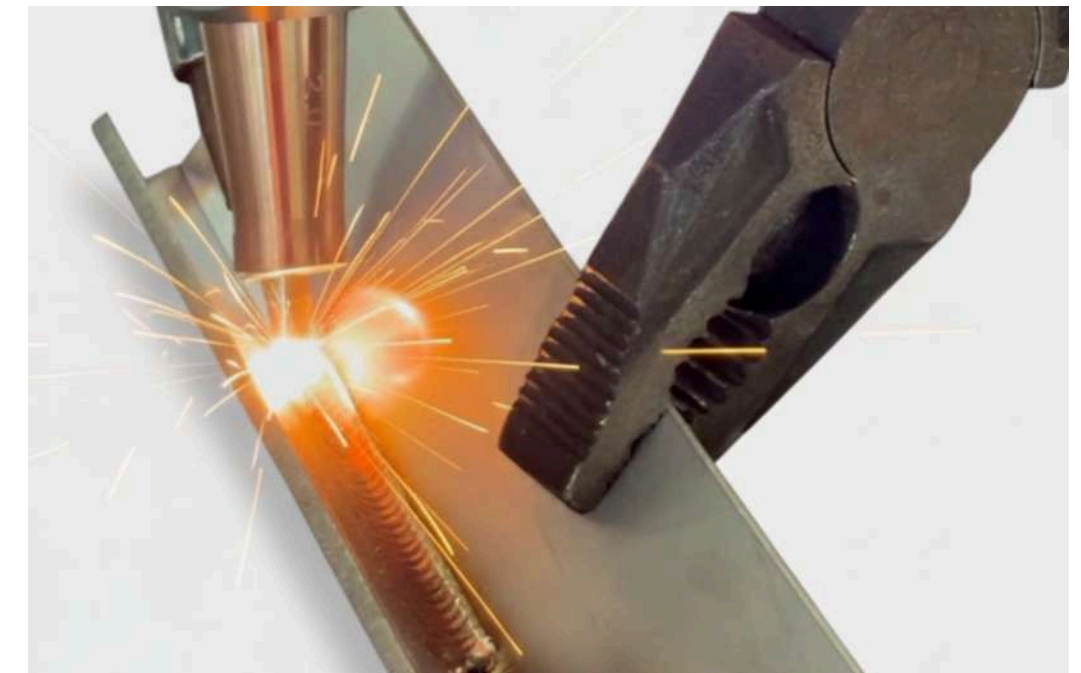

Fish-Scale Pattern 



Carbon Steel Butt Welding 

Choose Kempson, Choose Better Cost-Effectiveness

Cost Center	Traditional Method	Kempson Solution
Shielding Gas	Continuous procurement costs	Zero cost
Vulnerable Parts	Frequent replacement	8x longer service life Reusable
Subsequent Processes	Grinding required	Grinding eliminated
Downtime	High risk	Minimized

Smart Purchase, More Economical Operation

Technical Parameters

Model	KPS-ALW4000
Laser Power	4000W
Fillet Weld Thickness (Stainless Steel)	11mm
Fillet Weld Thickness (Carbon Steel)	12mm
Fillet Weld Thickness (Aluminum Alloy)	10.5mm
Wire Diameter	Φ0.8–2.0mm
Wire Feeding Mode	Automatic Wire Feeding (with Single/Double/Triple Wire Switching)
Total Power Consumption	≤6.2kW
Cooling Method	Built-in water cooling
Power Requirement	380v
Equipment Dimensions	0.7*1.1*1.3m
Equipment Weight	≈585kg
Weld Bead Width	8mm

The hand-held welding head is equipped with a 10-meter optical fiber as standard, enabling flexible and convenient outdoor long-distance welding.

Deeply Engaged in the Laser Welding Track

More Than 30 Patents Build a Solid Technological Moat

28

Utility Model Patents

4

Appearance Patents

1

Invention Patent

Patent NO.

[ZL202130808753.6]

[ZL202321366809.7]

[ZL202320242516.1]

[ZL202221937026.5]



Three-in-One Certification Guarantee

Possesses CE, FDA product certifications, and ISO Quality Management System Certification, providing you with globally recognized safety and quality commitments.



[20224Q20169R05]

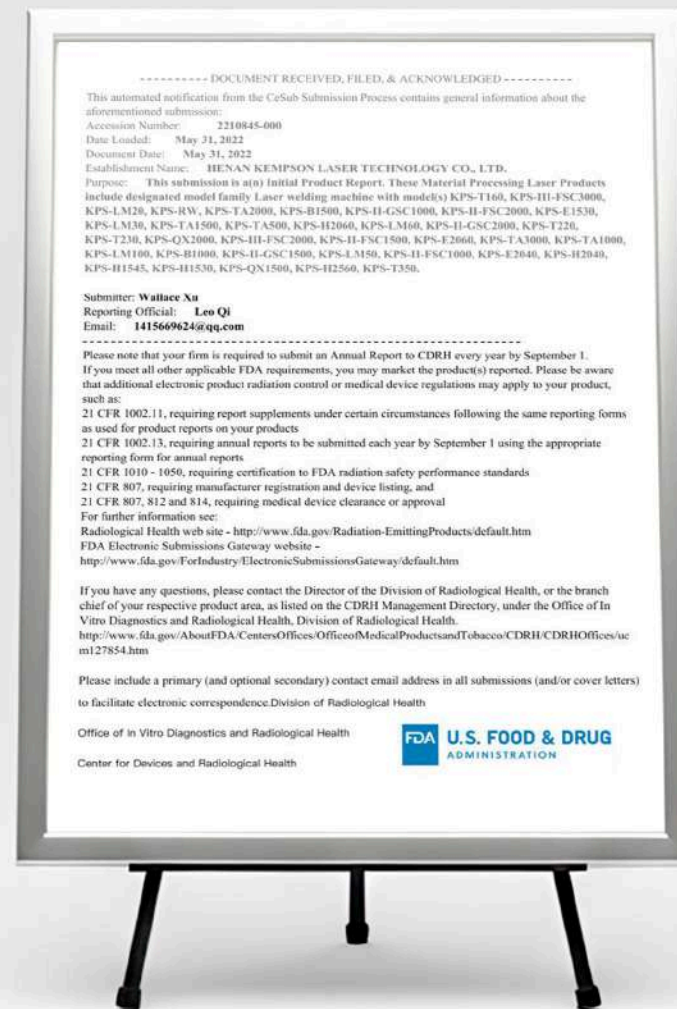

[2210845-000]



[ICR Polska/VC/HX220504]

Empowering Thousands of Industries

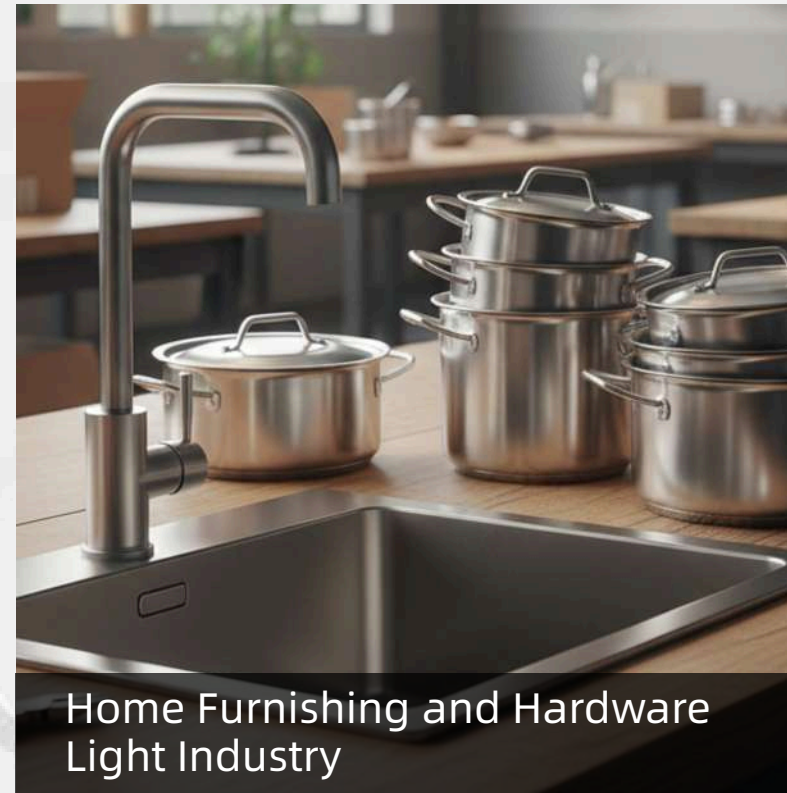
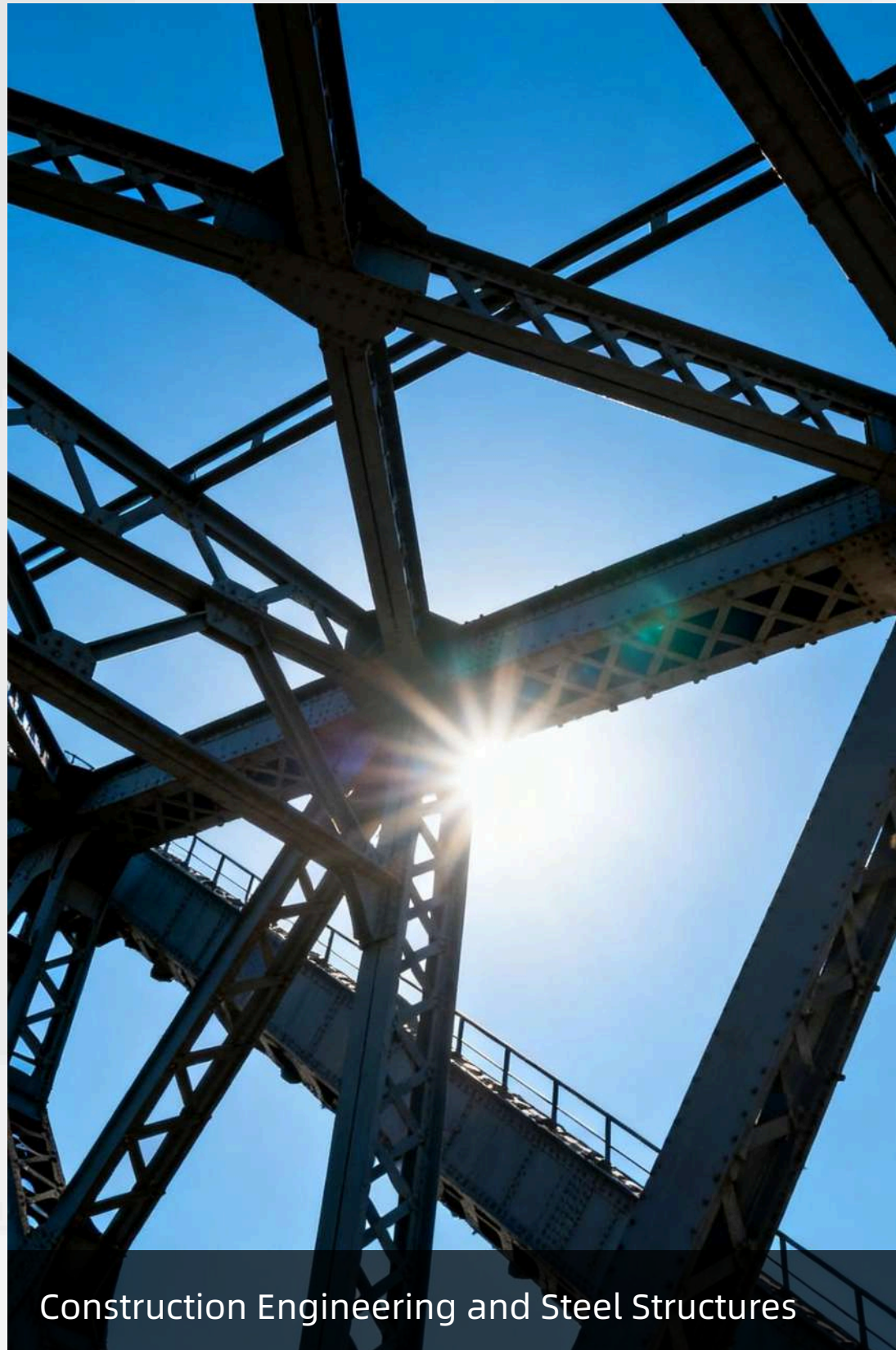

Kem
Kempson Anime IP Ambassador



Cooperate with Kempson Embark on a New Era of Efficient Welding

🌐 Website www.kempsonlaser.com

✉ Email carro.guo@kempsonlaser.com

☎ Telephone **+ 86 400-008-2255**

Kempson: Smart Procurement, More Economical Operation

Investing in Kempson means investing in a more efficient, stable, and cost-controllable production future.

We provide not just a piece of equipment, but a complete total lifecycle cost optimization solution.

